

TECHNICAL SPECIFICATION

SECTION: BATTEY AND BATTEY CHARGER

SECTION: BATTERY AND BATTERY CHARGER

Table of contents

Clause No.	Description	Page No.
1.1	GENERAL TECHNICAL REQUIREMENTS	1
1.2	Battery	1
1.3	Battery Charger	6
	Annexure-I	11

SECTION: BATTERY & BATTERY CHARGER

1.1. GENERAL TECHNICAL REQUIREMENTS

1.1.1. All materials/components used in battery chargers and batteries shall be free from flaws and defects and shall conform to the relevant Indian/IEC standards and good engineering practice.

1.1.2. **For 765, 400 & 220 kV sub-stations**, DC System shall consist of two(2) float-cum-boost chargers and two(2) battery sets for each of 220V and 48 V systems respectively. The standard scheme drawing is enclosed with this specification.

1.1.3. **For 132 kV sub-stations**, DC System shall consist of two(2) float-cum-boost chargers and two(2) battery sets for 220V/110V system. For 48 V system, DC scheme shall consist of one (1) battery and two(2) float-cum-boost chargers. The standard scheme drawing is enclosed with this specification.

1.1.4. Bidder shall select number of cells, float and Boost voltage to achieve following system requirement:

System Voltage	Maximum Voltage during Float operation	Minimum voltage available when no charger working and battery fully discharged upto 1.85V per cell.	Minimum Nos of cell
220 Volt	242 Volt	198 Volt	107
110 Volt	121 Volt	99 Volt	54
48 Volt	52.8 Volt	43.2 Volt	23

Bidder shall furnish calculation in support of battery sizing, selection of number of cells, float and Boost voltages during detailed engineering for Owners acceptance. Battery sizing calculations shall be done as per IEEE- 485 on the basis of following duty cycle:

	Load	Duration	Type Of Loads
220V DC System	Continuous Load	3 hours	Relays, IEDs, Station HMIs, spring charging, Isolator interlocking load, Miscellaneous permanently connected loads etc.
	Emergency Load	1 hour	Substation emergency lighting loads.
	Momentary Load	1 minute	Breaker closing, Tripping loads (taking simultaneous occurrence as per system)
48V DC System	Continuous Load	10 hours	Continuous load associated with PLCs.(when speech is not working)
	Momentary Load	15 minute	Loads associated with PLCs (when speech is working)

1.2. Battery

1.2.1. Type

The DC Batteries shall be VRLA (**Valve Regulated Lead-Acid**) type and shall be Normal Discharge type. These shall be suitable for a long life under continuous float operations and occasional discharges. Air-conditioning shall be provided in Battery room the requirement of which has been specified elsewhere in the Technical Specification. The 220 V DC system is unearth and 48 V DC system is + ve earth system.

1.2.2. Constructional Requirements

The design of battery shall be as per field proven practices. Partial plating of cells is not permitted. Paralleling of cells externally for enhancement of capacity is not permitted. Protective transparent front covers with each module shall be provided to prevent accidental contact with live module/electrical connections.

1.2.3. Containers

The container material shall have chemical and electro-chemical compatibility and shall be acid resistant. The material shall meet all the requirements of VRLA batteries and be consistent with the life of battery. The container shall be fire retardant and shall have an Oxygen Index of at least 28 %. The porosity of the container shall be such as not to allow any gases to escape except from the regulation valve. The tensile strength of the material of the container shall be such as to handle the internal cell pressure of the cells in the worst working condition. Cell shall not show any deformity or bulge on the sides under all working conditions. The container shall be capable of withstanding the rigours of transport, storage and handling. The containers shall be enclosed in a steel tray.

1.2.4. Cell Covers

The cell covers shall be made of suitable material compatible with the container material and permanently fixed with the container. It shall be capable to withstand internal pressure without bulging or cracking. It shall also be fire retardant. Fixing of Pressure Regulation Valve & terminal posts in the cover shall be such that the seepage of electrolyte, gas escapes and entry of electro-static spark are prevented.

1.2.5. Separators

The separators used in manufacturing of battery cells, shall be of glass mat or synthetic material having high acid absorption capability, resistant to sulphuric acid and good insulating properties. The design of separators shall ensure that there is no misalignment during normal operation and handling.

1.2.6. Pressure Regulation Valve

Each cell shall be provided with a pressure regulation valve. The valve shall be self re-sealable and flame retardant. The valve unit shall be such that it cannot be opened without a proper tool. The valve shall be capable to withstand the internal cell pressure specified by the manufacturer.

1.2.7. Terminal Posts

Both the +ve and –ve terminals of the cells shall be capable of proper termination and shall ensure its consistency with the life of the battery. The surface of the terminal post extending above the cell cover including bolt hole shall be coated with an acid resistant and corrosion retarding material. Terminal posts or any other metal part which is in contact with the electrolyte shall be made of the same alloy as that of the plates or of a proven material that does not have any harmful effect on cell performance. Both +ve and –ve posts shall be clearly and unambiguously identifiable.

1.2.8. Connectors, Nuts & Bolts, Heat Shrinkable Sleeves

Where it is not possible to bolt the cell terminals directly to assemble a battery, separate non-corroding lead or copper connectors of suitable size shall be provided to enable connection of the cells. Copper connections shall be suitably lead coated to withstand corrosion due to sulphuric acid at a very high rate of charge or discharge.

Nuts and bolts for connecting the cells shall be made of copper, brass or stainless steel. Copper or brass nuts and bolts shall be effectively lead coated to prevent corrosion. Stainless steel bolts and nuts can be used without lead coating.

All inter cell connectors shall be protected with heat shrinkable silicon sleeves for reducing the environmental impact including a corrosive environment.

1.2.9. Flame Arrestors

Each cell shall be equipped with a Flame Arrestor to defuse the Hydrogen gas escaped during charge and discharge. Material of the flame arrestor shall not affect the performance of the cell.

1.2.10. Battery Bank Stand

All batteries shall be mounted in a suitable metallic stand/frame. The frame shall be properly painted with the acid resistant paint. The suitable insulation shall be provided between stand/frame and floor to avoid the grounding of the frame/stand.

1.2.11. Capacity Requirements

When the battery is discharged at 10 hour rate, it shall deliver 80% of C (rated capacity, corrected at 27° Celsius) before any of the cells in the battery bank reaches 1.85V/cell.

The battery shall be capable of being recharged from the fully exhausted condition (1.75V/cell) within 10 hrs up to 90% state of charge. All the cells in a battery shall be designed for continuous float operation at the specified float voltage throughout the life.

The capacity (corrected at 27°Celsius) shall also not be less than C and not more than 120% of C before any cell in the battery bank reaches 1.75V/cell. The battery voltage shall not be less than the following values, when a fully charged battery is put to discharge at C/10 rate:

- (a) After Six minutes of discharge : 1.98V/cell
- (b) After Six hours of discharge : 1.92V/cell
- (c) After 8 hours of discharge : 1.85V/cell
- (d) After 10 hours of discharge : 1.75V/cell

Loss in capacity during storage at an average ambient temperature of 35° Celcius for a period of 6 months shall not be more than 60% and the cell/battery shall achieve 85% of its rated capacity within 3 charge/discharge cycles and full rated capacity within 5 cycles, after the storage period of 6 months. Voltage of each cell in the battery set shall be within 0.05V of the average voltage throughout the storage period. Ampere hour efficiency shall be better than 90% and watt hour efficiency shall be better than 80%.

1.2.12. Expected Battery Life

The battery shall be capable of giving 1200 or more charge/discharge cycles at 80% Depth of discharge (DOD) at an average temperature of 27° Celsius. DOD (Depth of Discharge) is defined as the ratio of the quantity of electricity (in Ampere-hour) removed from a cell or battery on discharge to its rated capacity.

1.2.13. Routine Maintenance of Battery system

For routine maintenance of battery system, the contractor shall supply 1 set of following tools:

- a) Torque wrench.
- b) Cell test voltmeter(-3-0-+3) volts with least count of 0.01 Volt.

1.2.14. Type Test of Battery

1.2.14.1. Contractor shall submit type test reports of following tests as per IEC 60896-21 & IEC 60896-22, 2004. The type test reports shall be submitted in accordance with the requirements stipulated in clause no. 9.2 of Technical Specification, Section: GTR except that the requirement of tests having been conducted within last five years as mentioned therein shall not be applicable).

S.No.	Description of test
1.	Gas emission
2.	High current tolerance
3.	Short circuit current and d.c. internal resistance
4.	Protection against internal ignition from external spark sources
5.	Protection against ground short propensity

6.	Content & durability of required markings
7.	Material identification
8.	Valve operation
9.	Flammability rating of materials
10.	Intercell connector performance
11.	Discharge Capacity
12.	Charge retention during storage
13.	Float service with daily discharges for reliable mains power
14.	Recharge behaviour
15.	Service life at an operating temperature of 40 ⁰ C for brief duration exposure time.
16.	Impact of a stress temperature of 60 ⁰ C for brief duration exposure time with 3 h rate discharge test.
17.	Abusive over-discharge
18.	Thermal runaway sensitivity
19.	Low temperature sensitivity
20.	Dimensional sensitivity at elevated internal pressure and temperature
21.	Stability against mechanical abuse of units during installation

Tests shall be conducted in accordance with IEC 60896-21 & IEC 60896-22, 2004

1.2.14.2. List of Factory & Site Tests for Battery

Sl. No.	Test	Factory Tests	Site Tests
1.	Physical Verification		√
2.	C/10 Capacity test on the cell	√	
3.	8 Hrs. Charge and 15 minutes discharge test at full rated load		√

1.2.15. Installation and commissioning

1.2.15.1. Manufacturer of Battery shall supervise the installation and commissioning and perform commissioning tests as recommended in O&M manual / or relevant standards. All necessary instruments, material, tools and tackles required for installation, testing at site and commissioning are to be arranged by Battery manufacturer/ Contractor

1.2.16. Contractor shall be submitted following documents for approval:

- a) Data sheet as per Annexure-I
- b) GA of cell and layout drawing

- c) Discharge Data for 10 Hour, 8 Hour, 3 Hour, 2 Hour, 1 Hour, 15 Minutes and One Minute indicating capacity factors for end cell voltage of 1.75 V & 1.85 V.
- d) Temperature correction factors
- e) Installation and commissioning Instructions
- f) O & M Manual

1.3. **Battery Charger**

The DC system for 220 V DC is unearthed and for 48 V DC is +ve earthed. The Battery Chargers as well as their automatic regulators shall be of static type and shall be compatible with offered VRLA batteries. All battery chargers shall be capable of continuous operation at the respective rated load in float charging mode, i.e. Float charging the associated Lead-Acid Batteries at 2.13 to 2.27 Volts per cell while supplying the DC load. The chargers shall also be capable of Boostcharging the associated DC Battery at 2.28 to 2.32 volts per cell at the desired rate.

Charger shall regulate the float/boost voltage in case of prescribed temperature rise of battery as per manufacturer's recommendation to avoid thermal runaway. Necessary temperature sensors shall be provided in mid location of battery banks and shall be wired up to the respective charger for feedback control. The manufacturer shall demonstrate this feature during testing of each charger.

- 1.3.1. All Battery Chargers shall be provided with facility for both automatic and manual control of output voltage and current. A selector switch shall be provided for selecting the mode of output voltage/current control, whether automatic or manual. When on automatic control mode during Float charging, the Charger output voltage shall remain within $\pm 1\%$ of the set value, for AC input voltage variation of $\pm 10\%$, frequency variation of $\pm 5\%$, a combined voltage and frequency variation of $\pm 10\%$, and a DC load variation from zero to full load.
- 1.3.2. All battery chargers shall have a constant voltage characteristics throughout the range (from zero to full load) at the floating value of the voltage so as to keep the battery fully charged but without harmful overcharge.
- 1.3.3. All chargers shall have load limiters having drooping characteristic, which shall cause, when the voltage control is in automatic mode, a gradual lowering of the output voltage when the DC load current exceeds the Load limiter setting of the Charger. The Load-limiter characteristics shall be such that any sustained overload or short circuit in DC System shall not damage the Charger, nor shall it cause blowing of any of the Charger fuses. The Charger shall not trip on overload or external short circuit.
- 1.3.4. Uniform and step less adjustments of voltage setting (in both manual and automatic modes) shall be provided on the front of the Charger panel covering the entire float charging output range specified. Step less adjustments of the Load-limiter setting shall also be possible from 80% to 100% of the rated output current for Charging mode.

- 1.3.5. During Boost Charging, the Battery Charger shall operate on constant current mode (when automatic regulator is in service). It shall be possible to adjust the Boost charging current continuously over a range of 50 to 100% of the rated output current for Boost charging mode.
- 1.3.6. The Charger output voltage shall automatically go on rising, when it is operating on Boost mode, as the Battery charges up. For limiting the output voltage of the Charger, a potentiometer shall be provided on the front of the panel, whereby it shall be possible to set the upper limit of this voltage any where in the output range specified for Boost Charging mode.
- 1.3.7. The Charger manufacturer may offer an arrangement in which the voltage setting device for Float charging mode is also used as output voltage limit setting device for Boost charging mode and the Load-limiter of Float charging mode is used as current setting device in boost charging mode.
- 1.3.8. Suitable filter circuits shall be provided in all the chargers to limit the ripple content (Peak to Peak) in the output voltage to 1%, irrespective of the DC load level, when they are not connected to a Battery.
- 1.3.9. MCCB**
- All Battery Chargers shall have 2 Nos. MCCBs on the input side to receive cables from two sources. Mechanical interlock should be provided such that only one shall be closed at a time. It shall be of P2 duty and suitable for continuous duty. MCCB's should have auxiliary contacts for annunciation.
- 1.3.10. Rectifier Transformer**
- The rectifier transformer shall be continuously rated, dry air cooled (A.N) and of class F insulation type. The rating of the rectifier transformer shall have 10% overload capacity.
- 1.3.11. Rectifier Assembly**
- The rectifier assembly shall be fully/half controlled bridge type and shall be designed to meet the duty as required by the respective Charger. The rectifier shall be provided with heat sink having their own heat dissipation arrangements with natural air cooling. Necessary surge protection devices and rectifier type fast acting HRC fuses shall be provided in each arm of the rectifier connections.
- 1.3.12. Instruments**
- One AC voltmeter and one AC ammeter along with selector switches shall be provided for all chargers. One DC voltmeter and DC ammeter (with shunt) shall be provided for all Chargers. The instruments shall be flush type, dust proof and moisture resistant. The instruments shall have easily accessible means for zero adjustment. The instruments shall be of 1.5 accuracy class. In addition to the above a centre zero voltmeter with selector switch shall also be provided for 220V chargers for testing purpose.

1.3.13. Air Break Switches

One DC output switch shall be provided in all chargers. They shall be air break type suitable for 500 volts AC/ 250 DC. The contacts of the switches shall open and close with a snap action. The operating handle of the switch shall be fully insulated from circuit. 'ON' and 'OFF' position on the switch shall be clearly indicated. Rating of switches shall be suitable for their continuous load. Alternatively, MCCB's of suitable ratings shall also acceptable in place of Air Break Switch.

1.3.14. Fuses

All fuses shall be HRC Link type. Fuses shall be mounted on fuse carriers which are in turn mounted on fuse bases. Wherever it is not possible to mount fuses on carriers, fuses shall be directly mounted on plug-in type base. In such case one insulated fuse pulling handle shall be supplied for each charger. Fuse rating shall be chosen by the Bidder depending on the circuit requirement. All fuses in the chargers shall be monitored. Fuse failure annunciation shall be provided on the failure of any fuse.

1.3.15. Blocking Diode

Blocking diode shall be provided in the positive pole of the output circuit of each charger to prevent current flow from the DC Battery into the Charger.

1.3.16. Annunciation System

Audio-visual indications through bright LEDs shall be provided in all Chargers for the following abnormalities:

- a) AC power failure
- b) Rectifier/chargers fuse blown.
- c) Over voltage across the battery when boost charging.
- d) Abnormal voltage (High/Low)
- e) Any other annunciation if required.

Potential free NO Contacts of above abnormal conditions shall also be provided for common remote indication "CHARGER TROUBLE" in Owner's ControlBoard. Indication for charger in float mode and boost mode through indication lamps shall be provided for chargers. A potential free contact for float/boost modes shall be provided for external interlocks.

1.3.17. Name Plates and Marking

The name plates shall be white with black engraved letters. On top of each Charger, on front as well as rear sides, larger and bold name plates shall be provided to identify the Charger. Name plates with full and clear inscriptions shall also be provided on and inside of the panels for identification of the various equipments and ease of operation and maintenance.

1.3.18. Charger Construction

The Chargers shall be indoor, floor-mounted, self-supporting sheet metal enclosed cubicle type. The Contractor shall supply all necessary base frames, anchor bolts and hardware. The Chargers shall be fabricated from 2.0mm cold rolled sheet steel and shall have folded type of construction. Removable gland plates for all cables and lugs for power cables shall be supplied by the Contractor. The lugs for power cables shall be made of electrolytic copper with tin coat. Power cable sizes shall be advised to the Contractor at a later date for provision of suitable lugs and drilling of gland plates. The Charger shall be tropicalised and vermin proof. Ventilation louvers, if provided shall be backed with screens. All doors and covers shall be fitted with synthetic rubber gaskets. The chargers shall have hinged double leaf doors provided on front and on backside for adequate access to the Charger's internals. All the charger cubicle doors shall be properly earthed. The degree of protection of Charger enclosure shall be at least IP-42 as per IS: 13947 Part I.

1.3.18.1. All indicating instruments, control switches and indicating lamps shall be mounted on the front side of the Charger.

1.3.18.2. Each Charger shall be furnished completely wired upto power cable lugs and terminal blocks and ready for external connections. The control wiring shall be carried out with PVC insulated, 1.5 sq.mm. stranded copper wires. Control terminals shall be suitable for connecting two wires, with 2.5 sq.mm stranded copper conductors. All terminals shall be numbered for ease of connections and identification. Each wire shall bear a ferrule or tag on each end for identification. At least 20% spare terminals shall be provided for control circuits.

1.3.18.3. The insulation of all circuits, except the low voltage electronic circuits shall withstand test voltage of 2 KV AC for one minute. An air clearance of at least ten (10) mm shall be maintained throughout for such circuits, right up to the terminal lugs. Whenever this clearance is not available, the live parts shall be insulated or shrouded.

1.3.19. Painting

All sheet steel work shall be pre-treated, in tanks, in accordance with IS:6005. Degreasing shall be done by alkaline cleaning. Rust and scale shall be removed by pickling with acid. After pickling, the parts shall be washed in running water. Then these shall be rinsed in slightly alkaline hot water and dried. The phosphate coating shall be 'Class-C' as specified in IS:6005. Welding shall not be done after phosphating. The phosphating surfaces shall be rinsed and passivated prior to application of stoved lead oxide primer coating. After primer application, two coats of finishing synthetic enamel paint of shade-692 (smoke grey) of IS:5 shall be applied, unless required otherwise by the Owner. The inside of the chargers shall be glossy white. Each coat of finishing synthetic enamel paint shall be properly staved. The paint thickness shall not be less than fifty (50) microns.

1.3.20. TESTS

1.3.20.1. Battery chargers shall conform to all type tests as per relevant Indian Standard. Performance test on the Chargers as per Specification shall also be carried out on

each Charger as per specification. Rectifier transformer shall conform to all type tests specified in IS : 4540 and short circuit test as per IS:2026. Following type tests shall be carried out for compliance of specification requirements:

- i) Voltage regulation test
- ii) Load limiter characteristics test
- iii) Efficiency tests
- iv) High voltage tests
- v) Temperature rise test
- vi) Short circuit test at no load and full load at rated voltage for sustained short-circuit.
- vii) Degree of protection test
- viii) Measurement of ripple by oscilloscope.
- ix) Temperature compensation feature demonstration

1.3.20.2. The Contractor may be required to demonstrate to the OWNER that the Chargers conform to the specification particularly regarding continuous rating, ripple free output, voltage regulation and load limiting characteristic, before despatch as well as after installation at site. At site the following tests shall be carried out :

- i) Insulation resistance test
- ii) Checking of proper annunciation system operation.

1.3.20.3. If a Charger fails to meet the specified requirements, the Contractor shall replace the same with appropriate Charger without affecting the commissioning schedule of the Sub-station, and without any extra cost to the OWNER.

1.3.20.4. The Contractor shall present for inspection, the type and routine test certificates for the following components whenever required by the OWNER.

- (i) Switches.
- (ii) Relays/ MCCBs
- (iii) Instruments.
- (iv) DC fuses.
- (v) SCR.
- (vi) Diodes.
- (vii) Condensers.
- (viii) Potentiometers.
- (ix) Semiconductor
- (x) Annunciator.
- (xi) Control wiring
- (xii) Push buttons and contactors.

Makes of above equipment shall be subject to Owner's approval.

Annexure-I

BATTERY SYSTEM DATA SHEETS

S.No.	Description of Data	Unit	220 V/ 110 V	48 V
1	General Data			
a)	Battery Type:			
	Grid alloy: Pure lead(Pb), lead calcium (Pb-Ca),lead antimony (Pb-Sb), or lead selenium (Pb-Se) or other pl. specify			
	Cell type: Absorbed glass mat or gel cell or other please specify			
	Seller's type number			
	Number of positive plates per cell			
b)	Does each battery and battery [rack]/ [cabinet] meet the seismic requirements	[Yes] [No]		
c)	Manufacturer's Designed Life of Battery	Yrs		
d)	Recommended Battery Charger Data:			
	Floating voltage range	V		
	Boost charge	V		
	Current rating	Amps.		
	Recharge time	hr		
e)	Heat Released During:			
	Discharge duty cycle	Watt		
	Float charge	Watt		
	Boost Charge	Watt		
f)	Maximum Amount of Hydrogen Gas Evolved			
	During Battery-Boost Charge (2.33 V per cell) at Maximum Battery Temperature	(Litre /h)		
	Hydrogen Gas Evolution at Float	(Litre /h)		
g)	Time Battery may be Stored Without a Freshening Charge	months		
h)	Temperature Compensation Provided and its Details			

S.No.	Description of Data	Unit	220 V/ 110 V		48 V	
2.	Physical Description.					
a)	Battery Cell:					
	Size (L x W x H)	mm				
	Weight	Kg				
	Volume of electrolyte gal	L				
	Jar cover material					
	Jar container material					
	Separator material					
	Retainer material					
	Limiting-oxygen index (LOI)					
b)	Battery [Rack] [Cabinet]:					
	Outline or catalog number					
	Quantity of [racks][cabinets] for the battery					
	Description (tier or step type)					
c)	Total Net Weight of Battery Including [Racks] [Cabinets]	kg				
d)	Total Shipping Weight of Each Battery Jar and Associated Equipment	kg				
e)	Connectors:					
	Intercell:					
	Type					
	Material					
	No. per connection					
	Inter-[Tier] [Step]:					
	Type					
	Material					
	No. per connection					
	Terminal Detail:					
	Type					
	Material					
f)	Terminal Lugs for Power Cable:					
g)	Torque Data:		Initial Torque Value	Re-torque Value	Initial Torque Value	Re-torque Value
	Intercell Connectors					
	Inter-[Tier] [Step]:					

S.No.	Description of Data	Unit	220 V/ 110 V	48 V
3.	Performance Data.			
	Battery String Designation No. [1] []			
	Float Voltage Without Boost	V/cell		
	Float Voltage With Boost	V/cell		
	Boost Charge Voltage	V/cell		
	Recommended Frequency of Boost Charge			
	Recommended Duration of Boost Charge			
	Open-Circuit Voltage	V/cell		
	Short-Circuit Current at Battery Terminals at Float Voltage at (27°C):			
	Battery Discharge Characteristics	A or A /positive plate		
	Guaranteed Amp-Hour Capacity (at the 10-hr rate) to Specified Final Voltage	AH		
	One-minute	A/cell		
	Fifteen-minute	A/cell		
	One-hour	A/cell		
	Two-hour	A/cell		
	Three-hour	A/cell		
	Eight-hour	A/cell		
	Ten-hour	A/cell		
4.	Required operating environment.			
	Battery Room Ambient Temperature Range	(°C to °C)		
	Battery Room Ambient Design Temperature	°C		
	Battery Room Minimum/Maximum Design Temperature	(°C to °C)		
	Maximum temperature at which battery can be stored	°C		

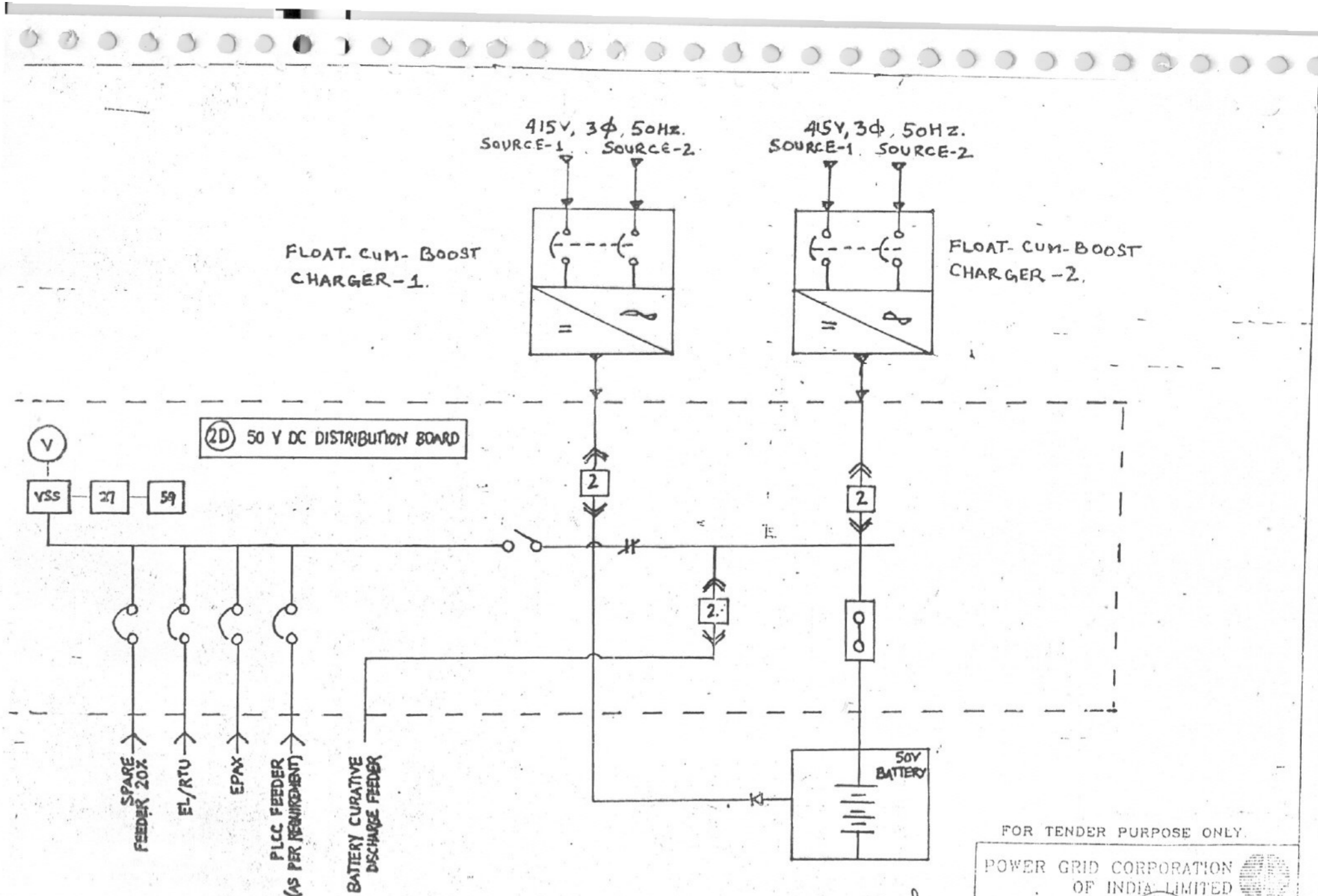

NOTE:-
 1. ELECTRICAL INTERLOCK SHALL BE PROVIDED BETWEEN SOURCE-1 & SOURCE-2 FOR EACH CHARGER

FOR TENDER PURPOSE ONLY.
 POWER GRID CORPORATION OF INDIA LIMITED
 AN GOVERNMENT OF INDIA ENTERPRISE
 STANDARD PRACTICE
 SCHEMATIC OF SOY CHARGER FOR 132KV S/STN

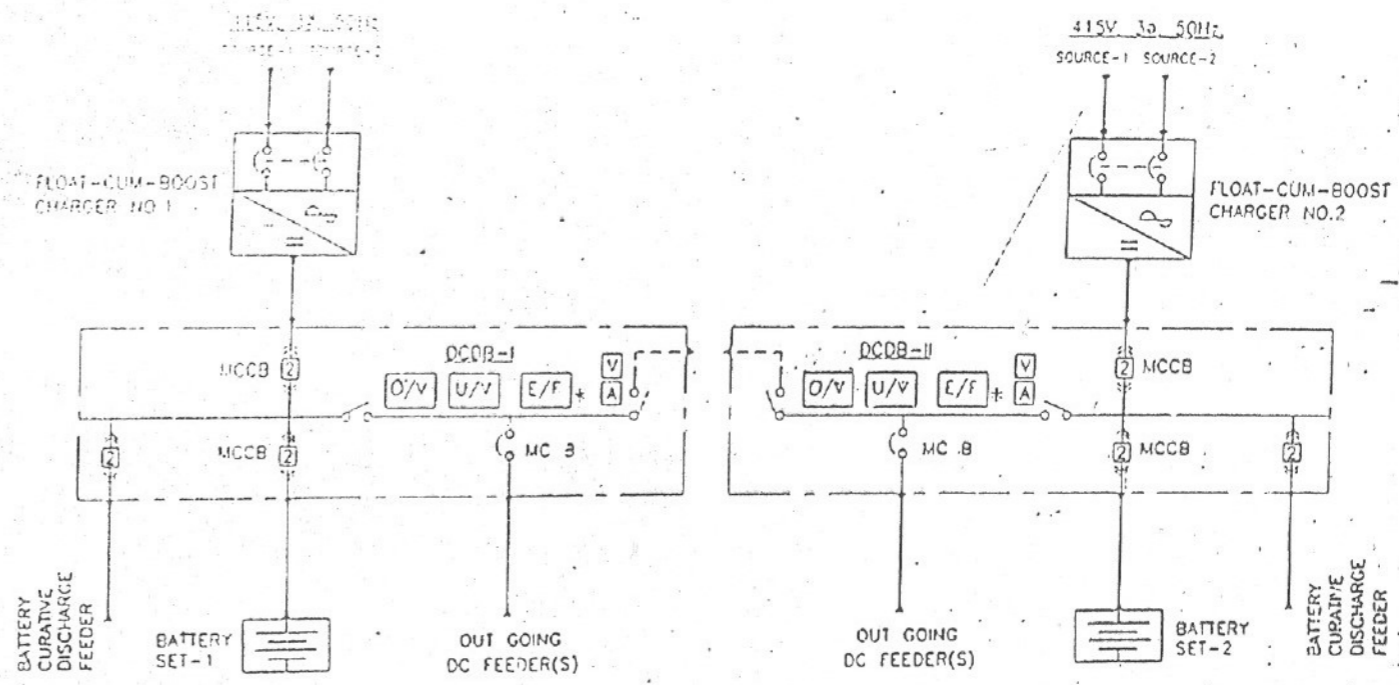

* ONLY FOR 110/220 V DC SYSTEM

- NOTE:**
- ELECTRICAL INTERLOCK SHALL BE PROVIDED BETWEEN SOURCE-1 & SOURCE-2 FOR EACH CHARGER.

JDOC-97C/PGCIL/GUPTA/SUB.DWG

POWER GRID CORPORATION OF INDIA LIMITED (A Government of India Enterprise)				
DRN.		PROJECT : STANDARDIZATION		
CHKD.		DRG. TITLE : STANDARD DC SYSTEM		
APPD.		DRAWING NO. C:/ENGG/STD/DC/01 (SH-1 OF 2)		
DEPT.		DATE	SCALE	REV
			NTS	2

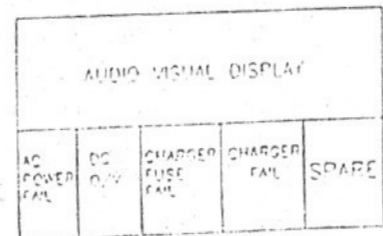
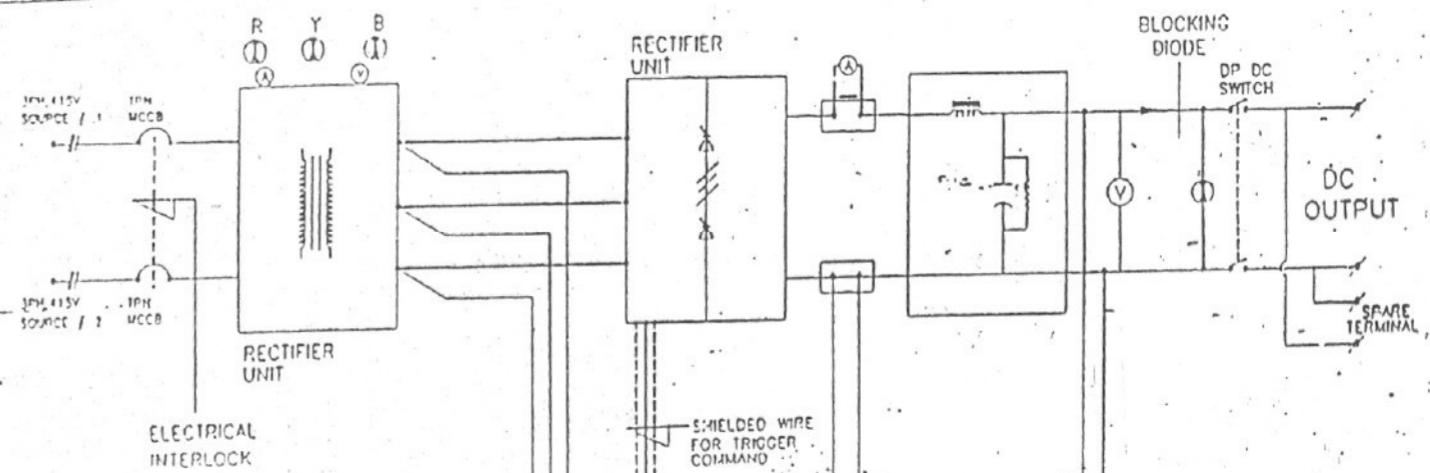

- A/M SELECTOR
- F/B SELECTOR
- GRADED CURRENT ADJ
- GRADED VOLTAGE ADJ

1. RIPPLE CONTENT IN THE OUTPUT SHALL BE WITH IN $\pm 1\%$ (p-p)
2. VOLTAGE REGULATION SHALL BE WITH IN 1% OF THE SET VALUE
3. SCHEMATIC SHOWN IS MINIMUM INDICATIVE REQUIREMENT OF CHARGER FOR DETAILED REQUIREMENT TECHNICAL SPECIFICATION MAY BE REFERRED.

POWER GRID CORPORATION OF INDIA LIMITED
(A Government of India Enterprise)

PROJECT 1	STANDARDIZATION
SCHEMATIC OF CHARGER	
0/1000/S11/20/01	

1000/S11/20/01
 0/1000/S11/20/01